

# Ignition! 8.1

by inductive automation

# The Digital Platform and Much More.



SCADA



IIoT



MES



HMI



Alarming



Reporting



Enterprise



Mobile



- Full Functionality Of Ignition.
- Unlimited Client
- Database Connectivity
- Multiple Project



SCADA



IIoT



MES



HMI



Alarming



Reporting



Enterprise



Mobile



- Lean Functionality Of Ignition.
- Limited Clients
- No database connectivity, with Limited internal data logging
- Possible to Run Only One Project



Edge Computing



Standalone HMI

# Ignition Architectures

## Basic Architecture



## Ignition Edge Panel: Standalone HMI

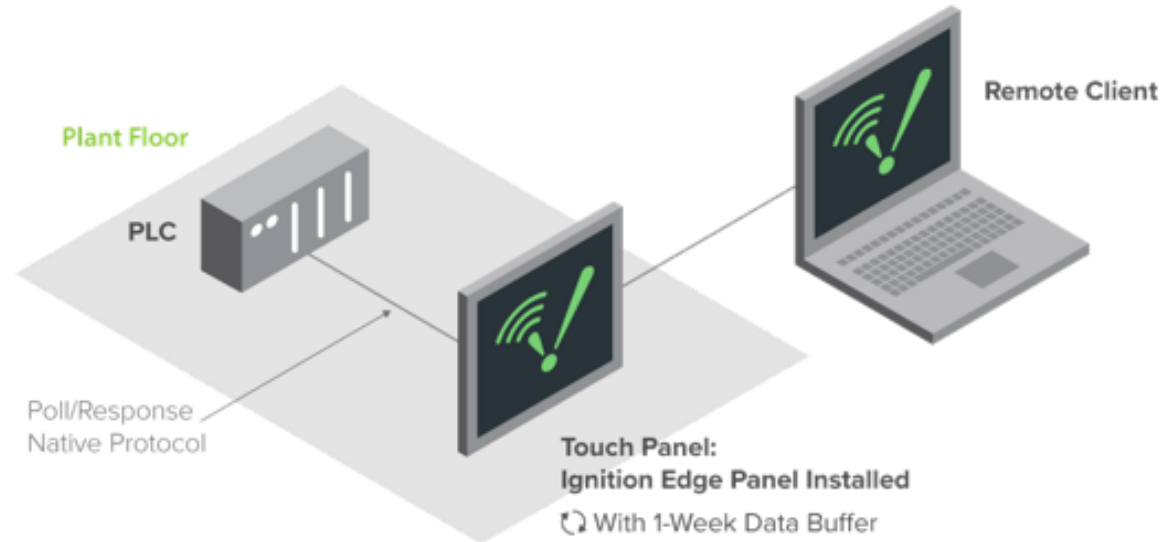

## Ignition Edge Sync Services

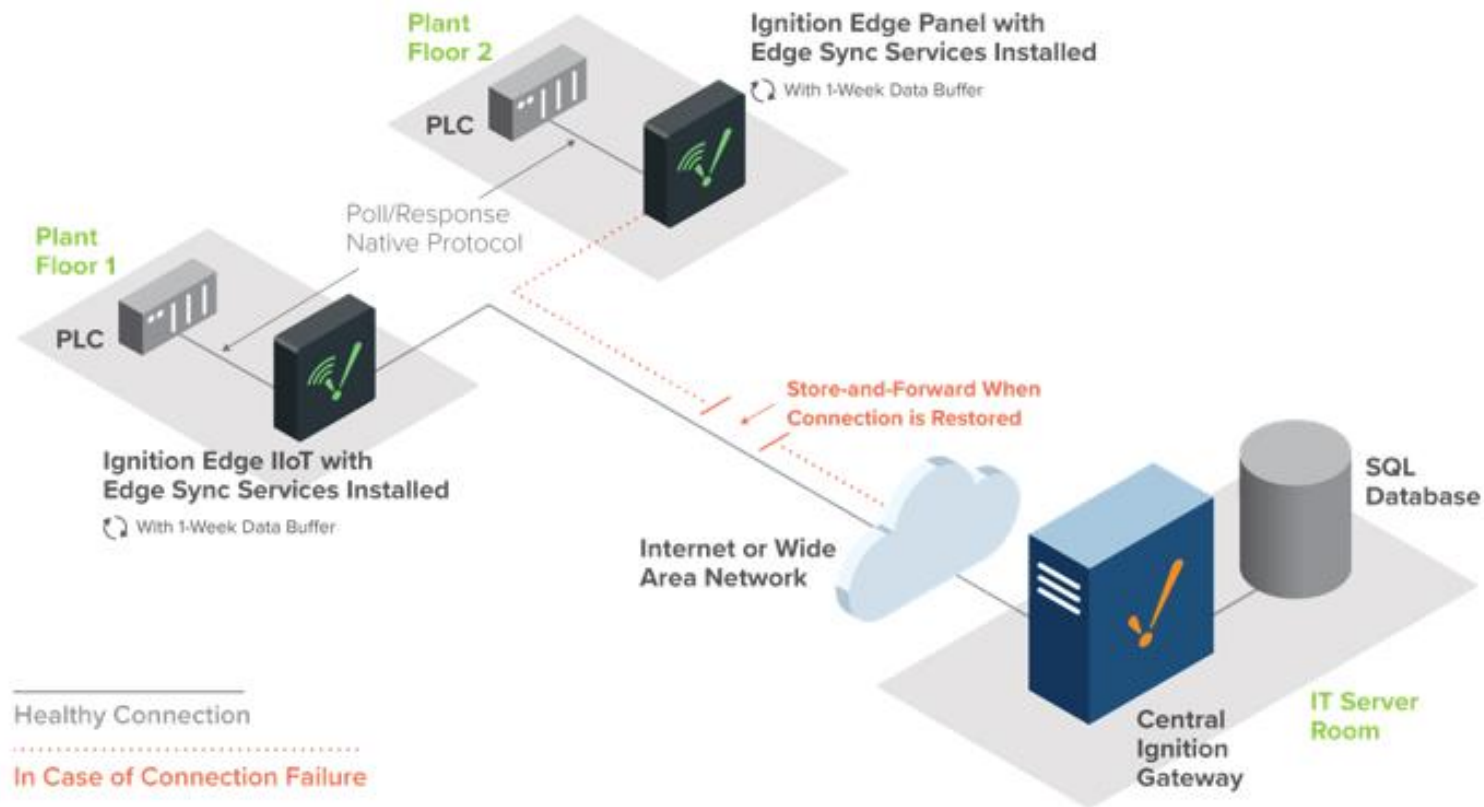

# Station Monitoring



Current Time: 10/26/2023 01:02 AM

Logged In: susan

0 Alarms

- Lock Screen
- Switch User
- Logout

- Overview
- Task Management
- Reports
- Alarms

Overview

Filter susan

52

Faulted

Off

Auto

47

Faulted

Off

Auto

35

Faulted

Off

Auto

Station 8  
Northeast Station

49

Faulted

Off

Auto

48

Faulted

Off

Auto

Station 13  
Top Station

49

Faulted

Off

Auto

Station 14  
Bottom Station

49

Faulted

Off

Auto

Station 15  
Best Station

71

Faulted

Off

Auto

Station 20  
Backwards Station

51

Faulted

Off

Auto

**Station Details**

**Station 10**  
Master Station

Faulted

Off

Auto

Username	Task	Description
susan	Clean	Clean the station



Time	Display Path	Priority	Type	Status	Event Va...
2023-10-26 00:55:36	Station 10 Reverse Flow Rate	Low	Active	Unacknowledged	-17.79
2023-10-26 00:53:46	Station 10 Reverse Flow Rate	Low	Active	Unacknowledged	-0.58
2023-10-26 00:53:40	Station 10 Reverse Flow Rate	Low	Active	Unacknowledged	-12.91
2023-10-26 00:53:20	Station 10 Reverse Flow Rate	Low	Active	Unacknowledged	-2.80
2023-10-24 13:40:32	Station 10 Reverse Flow Rate	Low	Active	Unacknowledged	-5.50

# Station Monitoring

localhost:8088/data/perspective/client/AcmelInc



Task List Station List

Station 3  
West Station





Faulted Off Auto

Station 4  
Southwest Station



Faulted Off Auto

Station 5  
South Station



Faulted Off Auto

www.gudeltechnology.com



# Warehouse Management System(WMS)

Command Windows Help



1 Alarm      Current Time: 09/29/2566 19:17:24

Logged In: steve

Lock Screen  
Switch User  
Logout

- Overview
  - Orders
  - Stock and Inventory
  - Location Setting
  - Alarms
  - Administration
- Machine Overview      Crane Overview

Bay    13    14,380mm

Level   4    5,906mm

Fork DD   0    2mm

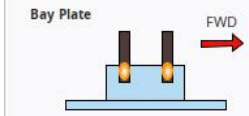
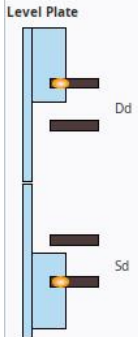
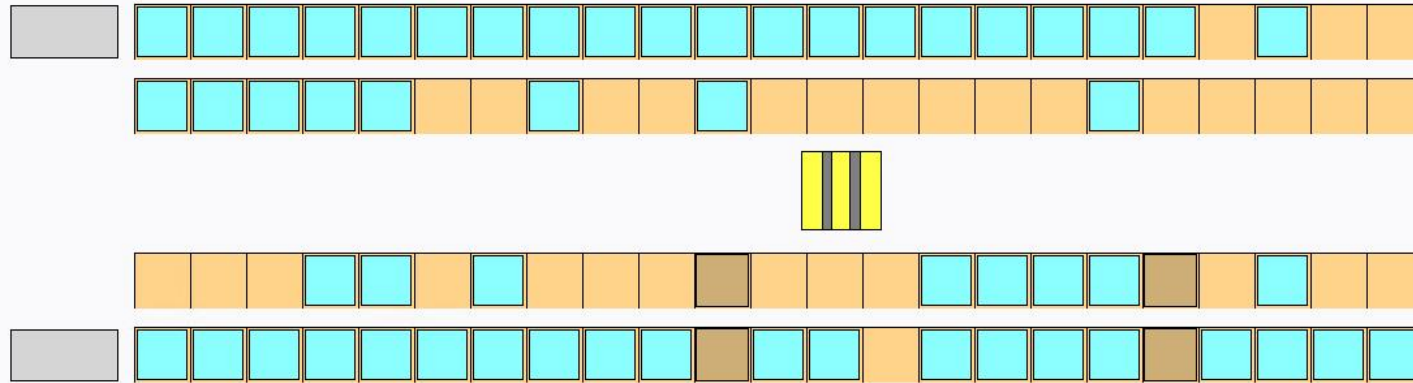

# Warehouse Management System(WMS)

Command Windows Help



1 Alarm

Current Time: 09/29/2566 19:15:42

- Lock Screen
- Switch User
- Logout

Logged In: steve

- Overview
- Orders
- Stock and Inventory
- Location Setting
- Alarms
- Administration

Search

0029

item_Number	Item_Description_Line1	Total_Qty	UOM
FGFDI0029	Frozen Dough Sausage Danish 48g (Halal)	126	Box
FGFPL0029	Butterfly Biscuit Original (Big C)	30	Box

rfid_tag_id	item_Number	quantity	U
E0040153004EAB42	FGFDI0029	15	B
E0040153004EFEF6	FGFDI0029	24	B
E0040150A88CEDF0	FGFDI0029	19	B
E0040153004F1311	FGFDI0029	18	B
E0040150A88E1471	FGFDI0029	17	B
E0040150A88DECE4	FGFDI0029	33	B

**Reports**

9/29/66 - 9/29/66

inbound\_01

**Inbound Item Reports**

From Sep 29, 2566  
To Sep 29, 2566

Item Number	Description	Quantity	UOM
FGFBRO010	Frozen Dough Chocolate Danish Bread 360g	21	Box
FGFCPL0009	Croissant Sandwich Dough (FA)	199	Box
FGFCPL0047	MARGARINE CROISSANT 30 g	515	Box
FGFCPL0048	Mini Butter Croissant 25 g	98	Box
FGFCPL0062	Frozen Dough RTB Mini Butter Croissant 25g (Type B)	3	Box
FGFDI0003	Chocolate Ship Stick 45 g	279	Box
FGFDI0011	Chocolate Custard Danish (Base d'au...	12	Box

	LEVEL	status	out_list
	6	ACTIVE	0:No Out Assigned
	4	ACTIVE	0:No Out Assigned
	6	ACTIVE	0:No Out Assigned
	6	ACTIVE	0:No Out Assigned
	2	ACTIVE	0:No Out Assigned
	2	ACTIVE	0:No Out Assigned

- Scan
- Report

# Water/ Wastewater

## Overview

Water / Wastewater Demo



- Dashboard
- Overview
- Chem Feed
- Filters

**FREEZER**  
1/18/24 10:49:29 AM

Active, Unacknowledged

NAME  
Freezer Suction Temp Too

PRIORITY High

VALUE -36.9766304035

Acknowledge

**BATTER MIXER**  
1/18/24 10:19:33 AM

Active, Unacknowledged

NAME Low Mixer Temp

PRIORITY Medium

VALUE 24.8194789886

Acknowledge

**WATER/TURBS/COMBTURB2**  
1/18/24 10:51:12 AM

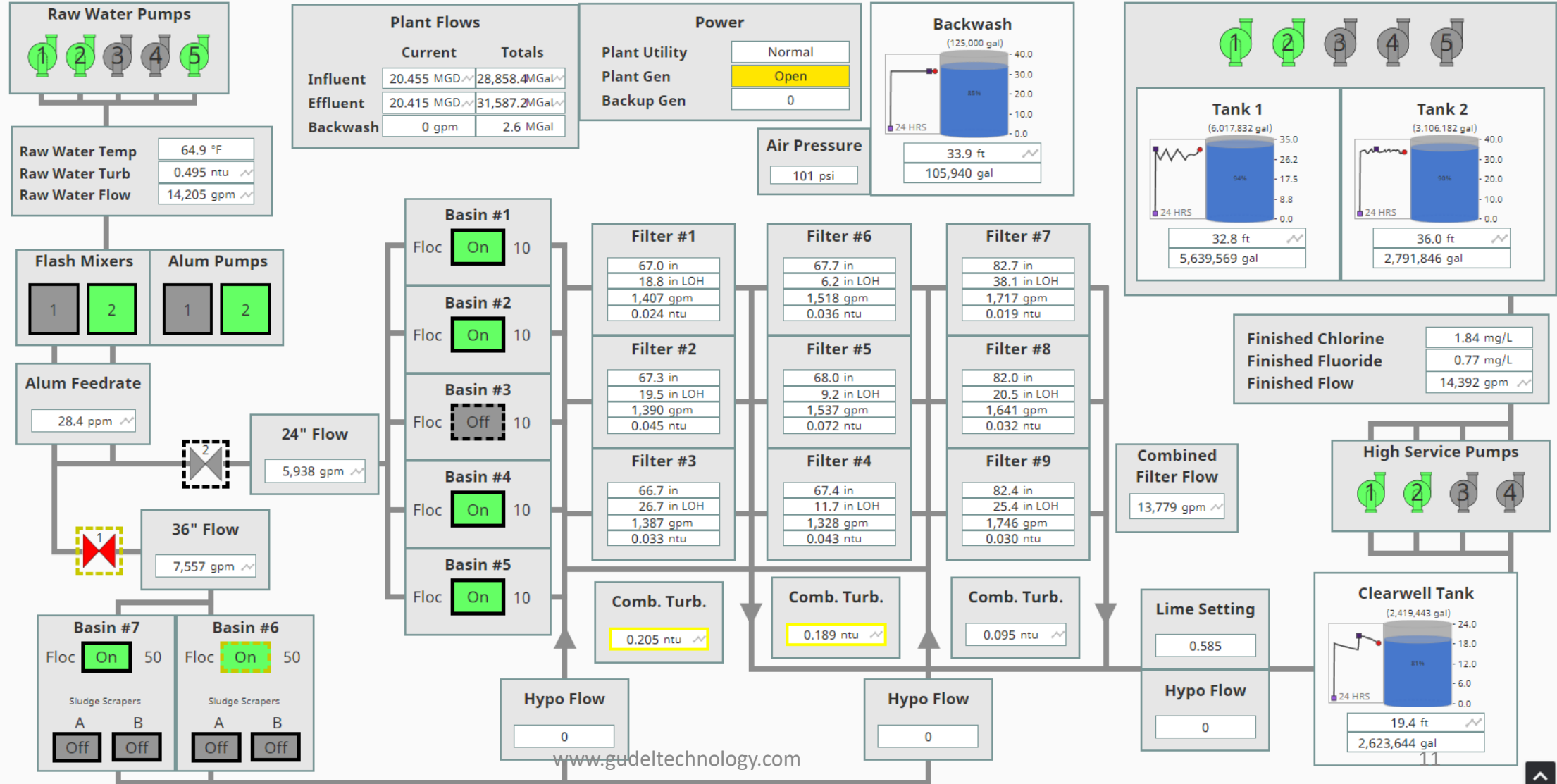



## Contact

Gudel Technology Co., Ltd.

19/28 Private Village, Huamark Road, Bangkapi District,  
Bangkok 10240 Thailand

kanokwan.klanbus@gmail.com

064-789-6915 ,089-444-6687 , 02-374-0709



@gudeltechnology